

W. SPELMAN.

ROW-LOCKS.

No. 190,793.

Patented May 15, 1877.

*Fig. 1.*

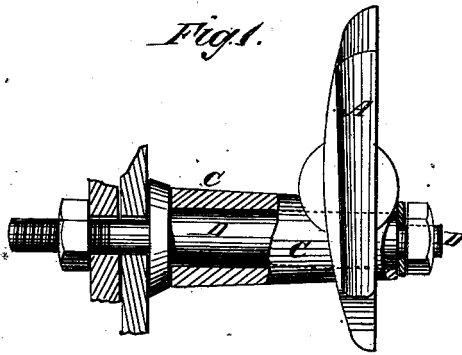

*Fig. 2.*

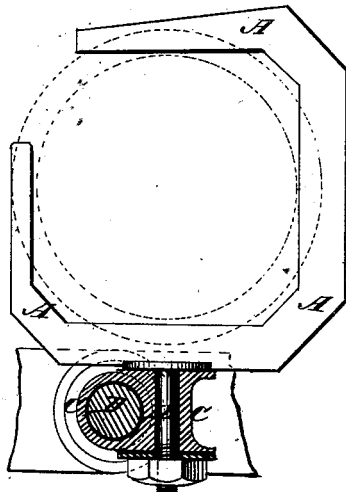

WITNESSES:

*Francis McArdle,*  
*J. H. Scarborough.*

INVENTOR:

*W. Spelman.*

BY

*Munn & Co.*

ATTORNEYS.

# UNITED STATES PATENT OFFICE.

WILLIAM SPELMAN, OF PORTLAND, MAINE.

## IMPROVEMENT IN ROWLOCKS.

Specification forming part of Letters Patent No. **190,793**, dated May 15, 1877; application filed April 2, 1877.

*To all whom it may concern:*

Be it known that I, WILLIAM SPELMAN, of Portland, in the county of Cumberland and State of Maine, have invented a new and useful Improvement in Oar-Locks, of which the following is a specification:

Figure 1 is a top view of my improved oar-lock, partly in section, to show the construction. Fig. 2 is a front view of the same, partly in section, to show the construction.

Similar letters of reference indicate corresponding parts.

The object of this invention is to furnish oar-locks which shall be so constructed as to diminish the friction between the oar and oar-lock, and which, at the same time, shall be simple in construction and easily applied to a boat.

The invention will first be described in connection with the drawing, and then pointed out in the claim.

A represents the oar-lock, which is made square, with its corners cut off, and an opening in its rear upper corner for the blade of the oar to be passed through. Upon the middle part of the lower or base bar of the lock A is formed a journal, B, which passes through, and works in, a hole in the pin-block C. The

pin-block C works upon the pin D, which has a screw-thread cut upon one end to receive the nut that secures it to the boat, and upon its other end to receive the nut that secures the pin-block C upon it. The journal B is also secured to the pin-block C by a nut screwed upon its lower end. The hole for the journal B is made a little at the inside of the hole for the pin D, to lessen the friction and keep the oar-lock A always square with the button of the oar when the strain is upon it.

The button of the oar should be made in the form of a ring, so as to rest squarely against all four sides of the oar-lock A, so that the oar and oar-lock may move together all the time.

Having thus described my invention, I claim as new and desire to secure by Letters Patent—

The combination, with pin D, attached to boat and oar-lock A, having the journal B, of the pin-block C, having the hole for journal B a little at the inside of the hole for the pin D, as and for the purpose specified.

WILLIAM SPELMAN.

Witnesses:

MICHAEL MITCHELL,  
DONALD A. MCINTOSH.