

J. P. HERRICK.
Construction of Boat.

No. 214,911.

Patented April 29, 1879.

Fig. 1.

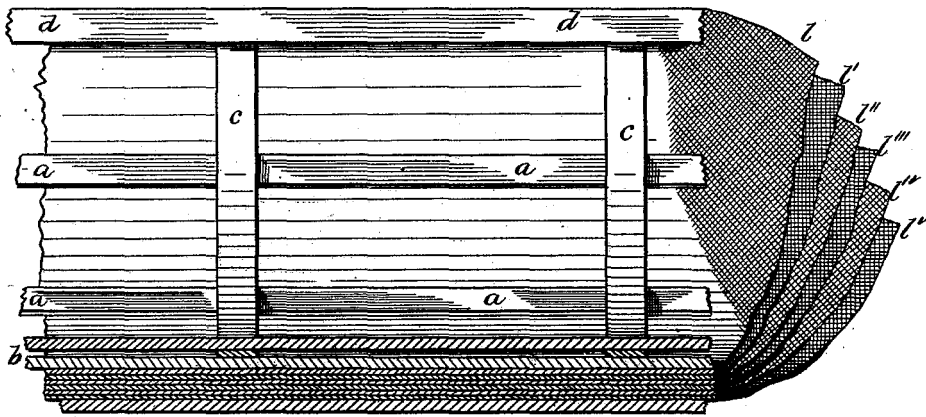

Fig. 2.

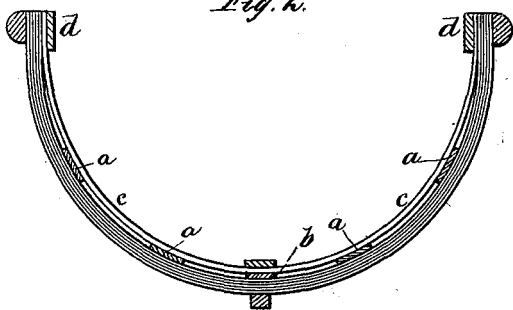

Fig. 3.

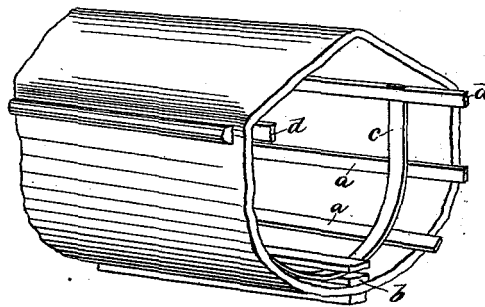
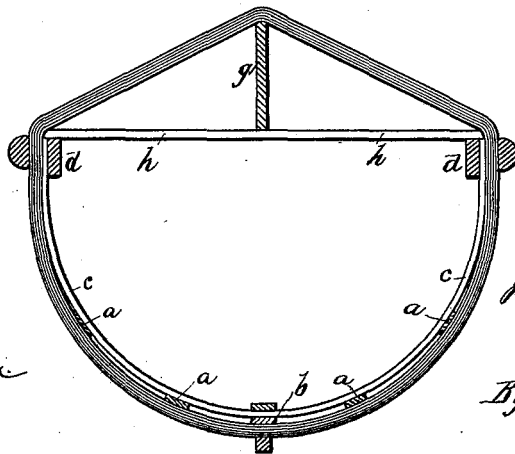

Fig. 4.



Attest:
Chas. H. Searle,
C. J. Morgan

John P. Herrick,
Inventor,
By Worth Clagwell,
Attorney.

UNITED STATES PATENT OFFICE.

JOHN P. HERRICK, OF WEST TROY, NEW YORK, ASSIGNOR OF ONE-HALF HIS RIGHT TO GEORGE F. HARDING, OF SAME PLACE.

IMPROVEMENT IN CONSTRUCTION OF BOATS.

Specification forming part of Letters Patent No. **214,911**, dated April 29, 1879; application filed March 12, 1879.

To all whom it may concern:

Be it known that I, JOHN P. HERRICK, of West Troy, county of Albany, and State of New York, have invented certain new and useful Improvements in Construction of Boats, of which the following is a full, clear, and exact description, reference being had to the accompanying drawings, and to the letters of reference marked thereon.

Figure 1 is a longitudinal section and elevation of a fragment of one side of a boat constructed in accordance with my improvements, the several layers of cloth of which the skin is composed being shown as separated from each other at the end of the fragment. Fig. 2 is a section upon a plane at right angles to the keel of a boat, which boat may, for the purposes of the present illustration, be regarded as of any desired form. Fig. 3 is a perspective view, and Fig. 4 a cross-section, of a fragment of a boat built after the form of the ordinary racing-sculls, having a portion decked over, and showing the application of my improvements to such forms.

These several figures—wherein like letters indicate corresponding parts—are chosen to illustrate the principles of my invention, representing, as they do, the outlines of the most ordinary styles of boats, and indicating clearly how the improvements may be applied to any desirable patterns.

Heretofore, and previous to my invention, in order to produce a smooth surface for contact of the boat with the water, and to render the structure light and easy to handle, the expedient of making the skin of several layers of paper has been resorted to, and this in a measure successfully, so far as mere smoothness and lightness are concerned. But the skins of boats so constructed are found to be unyielding to extraneous pressures, liable to be punctured through and through, owing to their brittleness, and when punctured are not capable of being easily repaired. The outer layer of paper is easily abraded, and when so damaged water enters between the layers, softening the cement and the inner layer, with which it comes in contact, causing a swelling or bulging out in the region of the damaged part, and thus gradually destroying the efficiency of the skin.

All this is attributable to the nature of the material, which, when the several layers are cemented together, is hard, brittle, and inelastic, and, owing to its texture, the cement cannot thoroughly penetrate the pores of each separate layer, but, on the contrary, adheres merely to the surfaces thereof; and in addition to these prominent objections to the manufacture of the so-called "paper boats," their construction involves the necessity of providing a heating or drying room, in which they must be subjected to a high temperature in order to prepare them for use, which adds materially to the cost and difficulty of manufacture. The paper skin necessitates a considerable stiffening in the direction of its length, which naturally adds to the weight of the completed structure. The skin must be formed of numerous strips of paper, which cannot be stretched, giving many seams or joints throughout the mass, and at points where a continuity of surface is desirable; and when exposed to the heat of the sun, damage results from warping and cracking.

To obviate or overcome these several disadvantages, to produce a boat the skin of which shall be sufficiently elastic to yield to ordinary extraneous pressures, and at the same time rigid enough so that with lighter strips it will maintain its proper form, tough enough to resist abrasion, not liable to further damage by moisture when abraded, and one cheap and easy to construct, with a minimum number of seams or joints in its several layers, are among the most important features or objects of my invention; and to accomplish these several objects, my invention consists, essentially, in forming the skin of the boat of several layers of woven or otherwise fabricated cotton or other suitable cloth, properly cemented together, involving certain peculiarities of manipulation and constructions, combinations, or arrangements of parts, all of which will be hereinafter first fully described, and then pointed out in the claims.

The frame of the boat, consisting of the usual, but very light, longitudinal strips *a a a a*, keelson *b*, ribs *c*, and gunwale-strip *d*, is properly secured to the form.

If it be desired to construct an ordinary,

shaped boat, such as indicated by the section, Fig. 2, I first secure a layer of cloth, preferably of the kind known as "cotton drilling," upon the frame, stretching it so that it will be quite smooth and conform to the general contour of the frame without making any cuts or joints in it. To facilitate this stretching and fitting, the cloth may be previously dampened, and the upper edges may be tacked in place upon any convenient portion of the form, or upon a strip specially provided for the purpose; or it may be otherwise suitably held in place at top. This first layer (*l* in the drawings) is then thoroughly saturated with a cement composed of glue and bichromate of potash, which, when it becomes hardened, is unaffected by water, is not brittle, does not injuriously affect the cloth, and thoroughly penetrates all the pores thereof. Before this coating of cement becomes dry the second layer of cloth, *l'*, is stretched upon the first, and saturated with a similar solution of glue and bichromate of potash; and the third layer, *l''*, is similarly located and saturated, as are also the remaining layers, (however many there may be,) except the outer one or protector, *l'''*.

For all general purposes six layers of cloth will be found sufficient; but the skin would, of course, be made heavier and stronger by increasing the number of layers, and lighter by diminishing them. Fig. 1 indicates only six layers, *l l' l'' l''' l'''' l'''''*, and these are intended to be made more or less numerous, as desired.

After the desired number of interior layers are located and glued as above explained, the filler is next applied, and this filler consists of a solution of corn-starch, japan-varnish, boiled oil, and spirits of turpentine, the purpose of which is to thoroughly penetrate the mass of glued cloth, unite with the glue, and form a mass wholly impervious to moisture, and unalterable by the heat of the sun.

The filler is plentifully applied, both upon the outside and inside surfaces of the partially-completed skin. Upon the skin thus prepared I put two good coats of shellac-varnish, (outside and inside,) and then permit the whole to gradually dry by exposure to the air, or by "sunning" it, if convenient.

The mass, in gradually drying, shrinks upon the form much the same as rawhide would do, and conforms to it in shape very perfectly. After this much of the skin is thoroughly dried, the protector or last layer, *l'''*, is stretched in place, and the whole then treated with two more coats of the shellac-varnish, which effectually secures the last layer. The skin is then dried, and trimmed about the gunwale as necessity may require, the gunwale finished, the keel put in place, and the completed boat removed from the form ready to receive the fittings.

If desired, the outer layer, *l'''*, may be very highly polished by use of emery, pumice-stone, or other polishing mediums.

To form a decked boat the several layers of cloth are similarly treated. They are indi-

cated in place in Figs. 3 and 4, the deck being supported, in the usual way, by a light string-piece, *g*, resting upon the thwarts *h*, or in any preferred manner.

The edges of the cloth may be brought together at the gunwale or at the string-piece *g*; or the inner layers may be made (in some forms where practicable) of a continuous piece.

While I have particularly mentioned only two special classes of boats, it should be understood that the invention is applicable to life-boats and rafts, and generally to all classes of the smaller sorts. Air-chambers can be easily formed in the skin, or they may be made in the shape of separate cylinders, after the manner of forming the skin, and afterward separately applied.

By increasing or decreasing the number of layers of thicknesses of cloth, and by varying the dimensions of the frame-strips, &c., a boat may be made very light, as for racing purposes, or heavy enough to withstand all shocks or strains to which it is likely to be subjected. The lightness of the skin, together with its toughness and non-liability to damage when exposed to the sun, render it particularly advantageous for use in life-boats such as are usually carried upon steamships and other vessels.

While I have given the best methods now known to me of practically constructing the boats, it will be readily understood that the particular processes pointed out may be immaterially varied without departing from the spirit or principle of my invention, and that any cement composition may be applied, if suitable.

Should the improved boat-skin be perforated by any accident, it is very easily repaired by cutting out the several layers down to the inner one around the perforation, removing pieces of each layer, which diminish in size from the exterior to the interior. Patches of cloth are then cut to correspond in size and shape with the removed parts, carefully glued in place, the filler composition applied, dried, varnished, the exterior patch located and varnished and polished in accordance with the described method of forming the skin. The repaired part will be found to be practically as sound as the remainder.

When constructed substantially in accordance with the foregoing explanations, my improved boats are found, in actual practice, to admirably answer the several purposes and objects of the invention, as previously stated, and to withstand the injurious effects of heat and wear or usage better than any of previous constructions (either of wood, paper, or other light material) now known to me.

Having thus fully described my invention, what I claim as new, and desire to secure by Letters Patent, is—

1. In combination with the boat-frame, the herein-described boat-skin or skin and deck, (when decks are used,) composed of several layers of cotton or other cloth stretched upon

the frame and cemented together, substantially in the manner and for the purposes set forth.

2. In combination with a boat-skin or skin and deck, (when decks are used,) composed of several layers of cotton or other cloth, cemented together and stretched upon the boat-frame, in the manner explained, the outer layer or protector of cloth varnished and held in place, substantially in the manner and for the purposes set forth.

3. The method herein described of forming a completed boat-skin or skin and deck, (when decks are used)—that is to say, cementing to-

gether a number of layers of cloth or other woven fabric, which have been stretched upon the frame, applying a filler composition, varnishing, drying, and then applying the protector or outer layer, and again varnishing the whole and drying, all substantially in the manner and for the purposes explained.

In testimony that I claim the foregoing I have hereunto set my hand and seal in the presence of two witnesses.

JOHN P. HERRICK. [L. s.]

Witnesses:

G. F. HARDING,
C. D. WEAVER.